

Machining PLEXIGLAS®

Guidelines for Workshop Practice



Contents

Content	Page
1 General Remarks	3
1.1 Physical forms	3
1.2 Dimensional changes and internal stress	3
1.3 Masking Film	4
1.4 Marking Out	4
1.5 Subsequent Surface Protection	4
1.6 Machining Equipment	5
1.7 Tools	5
2 Cutting	5
2.1 Circular saws	5
2.2 Bandsaws	7
2.3 Scrollsaws / Fretsaws	8
2.4 Jigsaws	8
2.5 Handsaws	8
2.6 Die-Cutting and Guillotining	8
2.7 Scoring and Breaking	8
2.8 Laser Cutting	9
2.9 Waterjet Cutting	10
3 Drilling	10
3.1 Twist Drills	10
3.2 Special Drills and Countersinks	11
3.3 Hole Cutting	12
3.4 Threadcutting	13
4 Routing	13
4.1 Template Routing	15
4.2 Engraving	15
5 Turning	16
6 Filing - Deburring - Planing	18
7 Sanding and Polishing	19
7.1 Sanding	19
7.2 Polishing	19
8 Annealing	22
9 Cleaning and Care	23

Notes:

In addition to this publication, there are similar Guidelines for Workshop Practice on

- Forming PLEXIGLAS® (Ref. No. 311-2),
 - Joining PLEXIGLAS® (Ref. No. 311-3), and
 - Surface Treatment of PLEXIGLAS® (Ref. No. 311-4).
- for professional PLEXIGLAS® fabricators.

You can find valuable do-it-yourself hints on PLEXIGLAS® in

- Fabricating Tips for PLEXIGLAS® (Ref. No. 311-5).

Special leaflets are available on the properties and fabricating behavior as well as the applications of several of our products, for example

- multi-skin and corrugated sheets
- glazing with solid sheets
- noise barriers
- signage and lighting.

These can be obtained from your local authorized distributor.

When using our products, please observe

- local building codes and emissions laws
- applicable standards
- product liability imposed by law
- the guidelines of employers' liability insurance associations.

1 General Remarks

PLEXIGLAS® – the trademark for the acrylic (polymethyl methacrylate, PMMA) we were the first to introduce worldwide – is very versatile in use and also popular for its exceptionally good machining properties. PLEXIGLAS® **GS** is produced by casting, PLEXIGLAS® **XT** by extrusion.

Both types of material can be machined in nearly the same manner. This also applies to PLEXIGLAS® products for specific applications, such as **SOUNDSTOP** (for transparent noise barriers), or with special surfaces. These can be abrasion-resistant, textured, metallized, or coated, i. e. **HEATSTOP** (reflects solar heat), **SATINICE** (with satin surfaces) and **NO DROP** (water dispersing). Differences in machining behavior are noted in the respective section.

It is the aim of this brochure to help you achieve optimal forming results. If you have any questions about our information or the practical work based on it, contact your local authorized distributor or our **Technical Service** department. We ourselves will be grateful for any suggestions based on your experience in the field.

1.1 Physical Forms

We produce PLEXIGLAS® **GS** in the form of solid / flat sheets, blocks, tubes, and rods with smooth or velvety (PLEXIGLAS **SATINICE**®) surfaces.

PLEXIGLAS® **XT** is available as conventional and impact-modified acrylic (PLEXIGLAS **RESIST**®), as smooth, textured or matte (PLEXIGLAS® **Satin Ice**) solid / flat sheets, corrugated sheets, multi-skin sheets, mirror sheets, tubes, and rods as well as films.

Colored PLEXIGLAS® sheets are normally homogeneously colored.

Whether in standard or special sizes, all material packaged on pallets is labeled with information for correct storage and in-house transport. Generally speaking, PLEXIGLAS® is best stored indoors. All our sheets are masked with polyethylene film, which can be disposed of without any problem. In the case of outdoor storage, effective additional protection is required.

1.2 Dimensional Changes and Internal Stress

Machining affects the overall behavior of plastics parts. Thus, the stress that may be generated on the inside of machined areas can cause problems during subsequent work steps such as bonding, for example. This internal stress – just like that in molded parts – has to be relieved by annealing (see '8 Annealing').

Thermoforming normally causes the material to shrink as a result of the applied heat. The shrinkage in length and width may vary, depending on the material grade used, and has to be allowed for when cutting the workpiece to size. The maximum possible shrinkage values can be taken

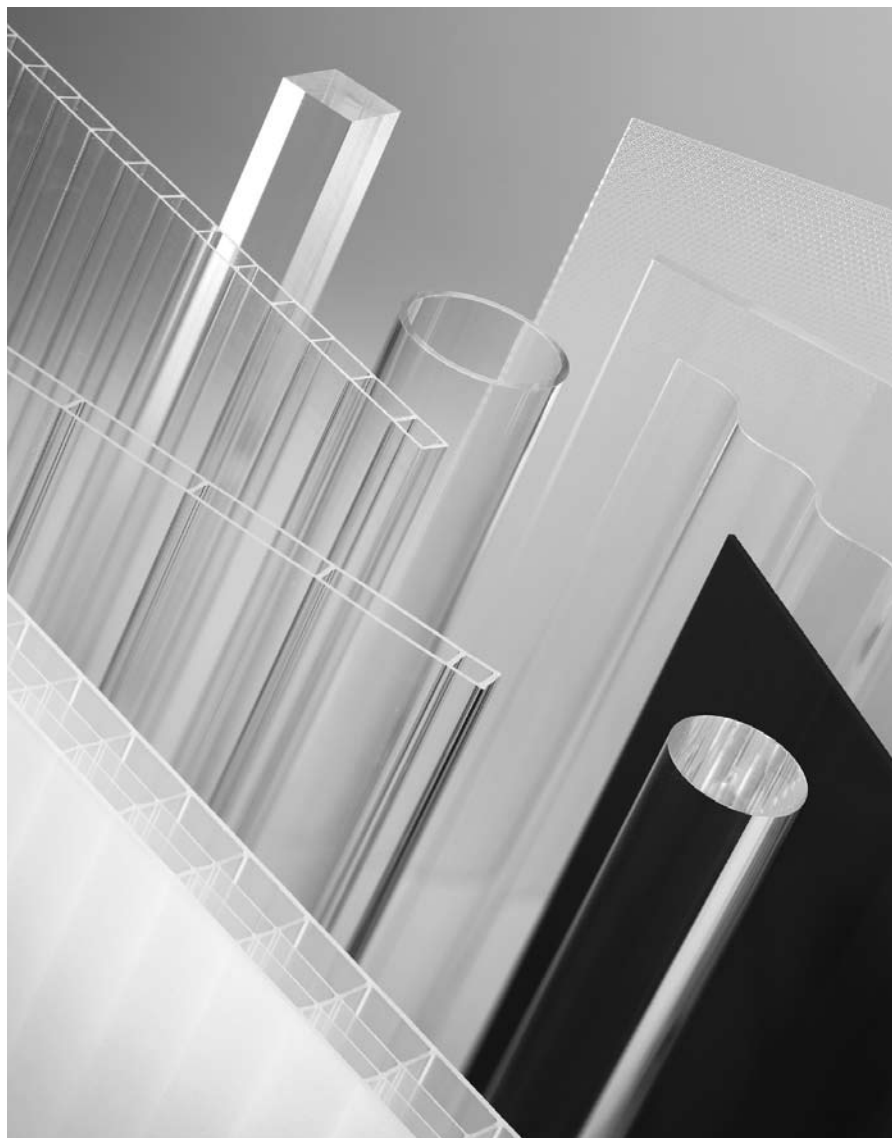

Fig. 1 Sales range overview

1 General Remarks

from our Sales Handbook, as well as from our Guidelines for Workshop Practice entitled „Forming PLEXIGLAS®.“

If only one sheet surface is mechanically treated, there may be some slight distortion of the workpiece. This can be reversed by **subsequent annealing** (see '8 Annealing'). In the case of more complex technical parts, distortion can be avoided altogether if the material is annealed at a temperature **above** its softening point **prior to** machining (see '8 Annealing').

Like most other plastics, acrylic also has a high coefficient of linear thermal expansion. The value is $0.07 \text{ mm/m} \cdot \text{K}$ for PLEXIGLAS® GS and XT. Moisture also has an influence on the dimensional stability, but less so than heat.

Example: An equipment part made of PLEXIGLAS® GS which is 1000 mm long undergoes a change in length of 1.4 mm ($20 \text{ K} \cdot [0.07 \text{ mm/m} \cdot \text{K}] \cdot 1 \text{ m}$) between 10°C and 30°C.

Therefore: Always check the dimensions of identical parts at the same ambient and material temperatures.

1.3 Masking Film

Depending on material grade and thickness, the surfaces of our sheets are masked with self-adhesive or cling film. Normally, the surface masking should remain on the sheet until it is in its final place. If the film must be removed before thermoforming or bonding: hold the sheet firmly down on one side and strip off the film with **one quick movement of the hand.**

When sheets are exposed to the weather, the masking films must be removed **within four weeks**, regardless of their adhesive properties, since polyethylene may become brittle after this period of time or adhere even more strongly. In either case the films can no longer be properly removed, and the sheets are likely to be damaged.

1.4 Marking Out

The environmentally friendly PE masking film is intended to protect PLEXIGLAS® sheets during transport and storage. This protective film should remain on the sheet during all machining operations, and is best left on until the finished part is in its final place.

Marking out of drill holes, contours or edges to be cut off is therefore done on the masking film. If the latter has already been removed, use special pencils (e.g. soft lead or grease pencils) for marking out directly on the sheet surface.

Scribers or prick punches should not be used unless it is ensured that the notches they cause are eliminated in a subsequent operation. Otherwise, all materials mentioned – even impact-modified PLEXIGLAS RESIST® – may crack or break under load.

1.5 Subsequent Surface Protection

When machined sheets, semifinished or finished parts – but also installed elements – made of PLEXIGLAS® need to be protected against soiling, chemical or other influences during further treatment or storage – e.g. for renovation purposes – the following measures can be recommended:

- coatings applied in liquid form which can later be stripped off as films (such as 30% aqueous solutions of PVAL) or protective films
- compatible adhesive crêpe tapes
- adhesive polyethylene films or
- polyethylene bags, which are then closed or heat-sealed.



Fig. 2: Marking out

1.6 Machining Equipment

PLEXIGLAS® can be machined with the equipment commonly used for wood-working and metalworking. Vibration-free, high-speed machines guarantee clean cuts. Sanding machines and circular saws in particular should be provided with a dust extractor / collector for immediate removal of swarf or chips.

High-quality, pneumatically powered tools are also used for machining.

1.7 Tools

PLEXIGLAS® is worked with HSS, carbide or diamond tools. Carbide tools are known to have the longest life, but it must be borne in mind that the pigments incorporated also in more densely colored PLEXIGLAS® may reduce any tool life very noticeably.

Blunt tools cause burred edges, chipping, material stress, etc. Cutters must always be sharply ground, paying particular attention to the clearance and rake angles. Tools previously used on wood or metal should therefore not be employed for plastics.

Only sharp tools should be used for machining PLEXIGLAS® and care be taken to provide adequate cooling.

Oil-free cooling lubricants can be used on PLEXIGLAS®. A concentration of approx. 4% in water is recommended.

2 Cutting

PLEXIGLAS® is normally cut to size by means of circular saws or bandsaws. Hacksaws and handsaws can also be used. **Cutting discs do not produce satisfactory results.**

Impact-modified materials such as PLEXIGLAS RESIST® can also be die-cut and guillotined, depending on thickness.

2.1 Circular Saws

Whereas plastics fabricators normally use circular table saws circular saws, vertical panel saws are common in the trade. Moreover, computer-controlled stack cutting lines are available for cutting larger lots to size. Given automatic feed, the quality of the cut will be noticeably improved. Other advantages are a uniform tool load, shorter machining times, and longer tool lives.

The blades of circular handsaws or of circular table saws should protrude only slightly beyond a PLEXIGLAS® sheet.

Other tips:

- never work without a stop;
- switch on the saw before carefully starting to cut;
- make sure the blade is guided accurately;
- do not tilt the material;
- secure the sheet against fluttering;
- work at an average feed rate.

PLEXIGLAS® from 3 mm thickness onwards should be cooled with water, cooling lubricant or compressed air.

Fig. 3 shows the correlation between cutting speed, saw blade diameter and saw rotational speed: a saw speed of 4,200 rpm, for example, is optimal if the blade has a diameter of 320 mm. The cutting speed is then 4,230 m/min.

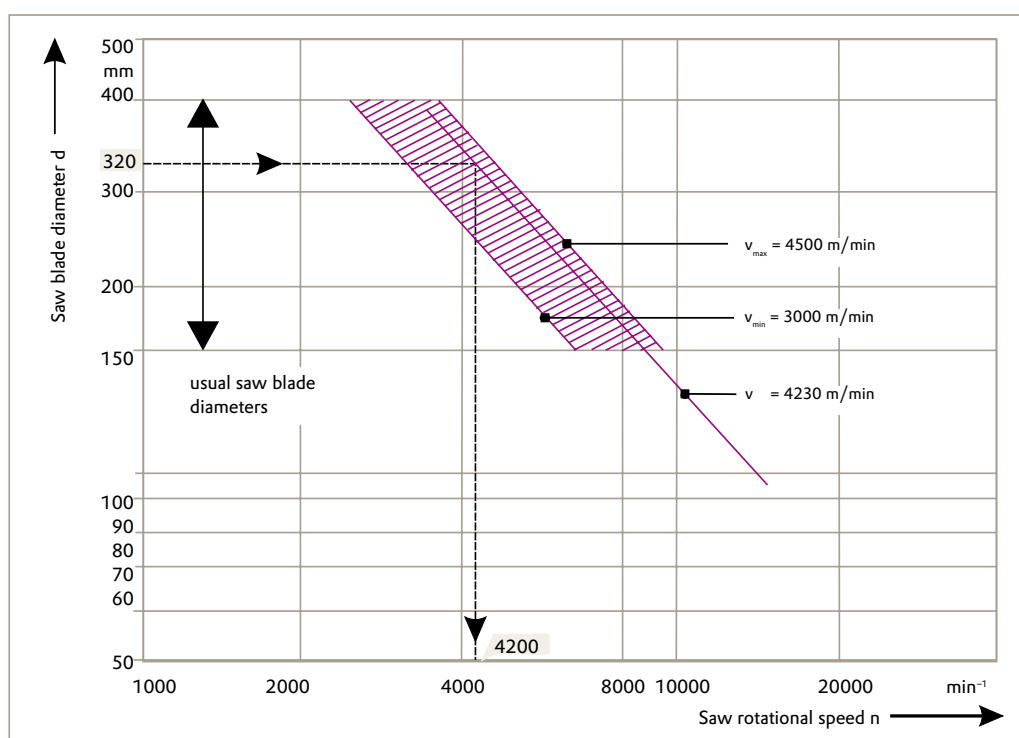

Fig. 3: Recommended cutting speeds, saw blade diameters, and saw rotational speeds for cutting PLEXIGLAS® on circular saws.

2 Cutting

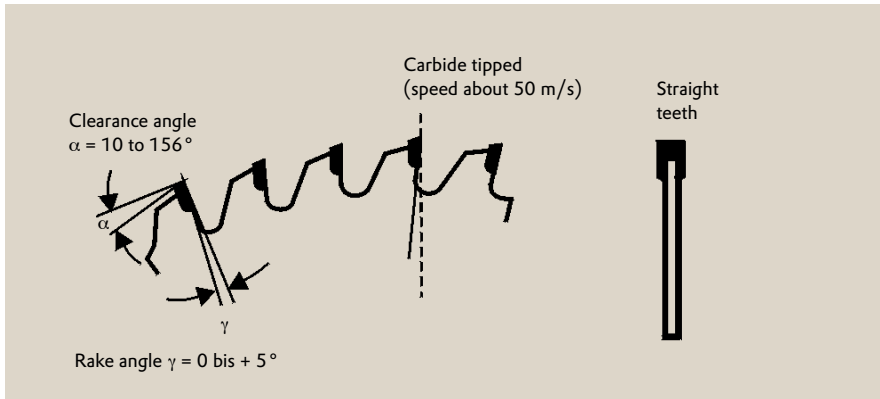

Fig. 4a: Circular saw blades

For circular saws (carbide-tipped blades):

Clearance angle α	10 to 15°
Rake angle γ	0 to 5°
Cutting speed v_c	up 4500 m/min
Tooth pitch	9 to 15 mm

For cutting PLEXIGLAS®, use only **unset** circular saw blades. This is the only way to ensure smooth and clean cut edges.

We recommend you to use only carbide-tipped blades with the largest possible number of teeth, also because they have a longer tool life than HSS blades. Blunt and incorrectly ground blades cause chipping on the underside of the workpiece. The teeth can be straight or alternately beveled (see Fig. 4).

Straight-toothed carbide blades cut less aggressively if both ends of each tooth, or of every other tooth, are bevel-ground (= trapezoidal flat tooth).

The feed of the saw must be set so as to prevent chipping at the cut edges. If the feed rate is too low, this may result in friction and thus unwanted heat buildup at the cut edges.

Circular saw blades with specially shaped tooth flanks ("Bombastic", "Spacecut") provide clean and smooth cut edges on PLEXIGLAS® when used in a sophisticated sawing machine operating with frequency and feed control, amongst other innovations.

For cutting PLEXIGLAS® XT in general, as well as thicker sheets and blocks of PLEXIGLAS® GS, circular saws should be equipped with a spray cooling unit, which can also be installed at a later stage. Based on the principle of a waterjet pump, the compressed air entrains the emulsion-based cooling and lubricating fluid and spreads it as a fine spray mist on the rotating blade. Fig. 5 shows such a unit.

Unfortunately, this type of cooling system is not often used in practice, either because there is not enough room under the machine table, or else because the employers' liability insurance association insists on the use of a splitting wedge, especially if the saw is used for different types of material. Sometimes problems are also caused by the cutting emulsion. Addi-

tional cleaning is required after subsequent printing, bonding, etc.

After running extensive test series, we found a standard saw blade belonging to the group recommended above which is **ideally suited for PLEXIGLAS® XT at a tooth pitch of approx. 13 mm.**

With this saw blade, even thick sheets and stacks of blanks can be cut **without additional cooling.** PLEXIGLAS® XT in every available thickness, including 25 mm, as well as even thicker sheet stacks were sawed without any problems. The cutting result is nearly independent of the feed rate. The stress generated in the cut edge is so low that the risk of **crazing is minimal**, an advantage the fabricator will appreciate during subsequent bonding.

The same saw blade can also be used on PLEXIGLAS® GS in every available thickness. However, its benefits become most obvious from a thickness of 3 mm onwards, and it should really be used when spray cooling cannot be performed. Generally speaking, lubricant cooling is still the most preferred method, provided the emulsion can be tolerated.

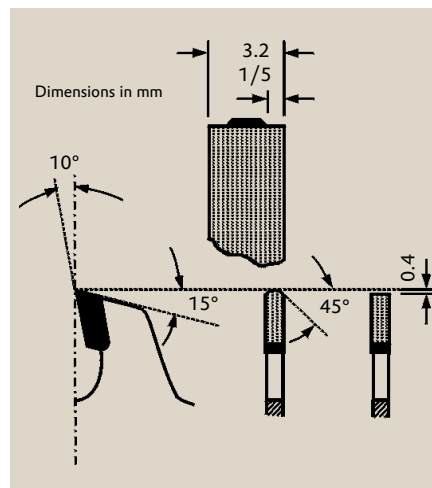
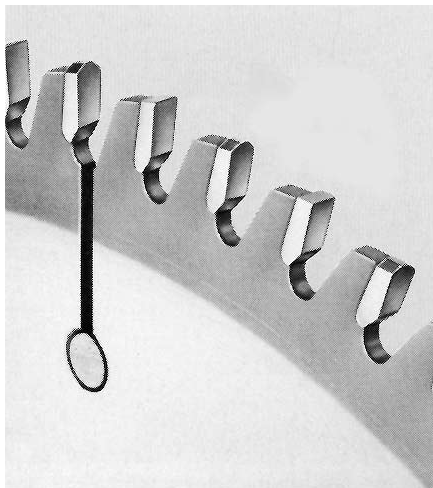

Fig. 4b: Optimized circular saw blade; tooth shape: trapezoidal flat, diameter: 300 mm, number of teeth: 72, tooth pitch: ~ 13 mm

2.2 Bandsaws

For contour cuts and trimming molded parts made of PLEXIGLAS®, fabricators often use the bandsaws commonly used in the wood and metal industry. Their blades are always slightly side-set, thus providing somewhat rougher edges than those obtained with circular saws, independent of material. Posttreatment of the edges is normally required. The width of the band blade, between 3 and 13 mm, depends on the desired contour cut and the type of saw used. The number of teeth should be between 3 and 8 per cm of band length. The band speed (cutting speed) can vary from 1000 to 3000 m/min. (see Fig. 6).

As a rule of thumb, the number of teeth should be increased with decreasing cutting speed.

While sawing, care must be taken that the sheets are secured against flutter and vibration.

Fig. 6 shows that the ideal cutting speed is 1675 m/min, for example, if the diameter of the bandsaw wheel is 380 mm and the working spindle rotates at 1,400 rpm.

When using horizontal bandsaw blades for trimming the edges of molded parts, blades over 13 mm wide can be guided more effectively. Make sure that the molded parts are firmly held in position on a support of identical design in order to prevent sudden splitting.

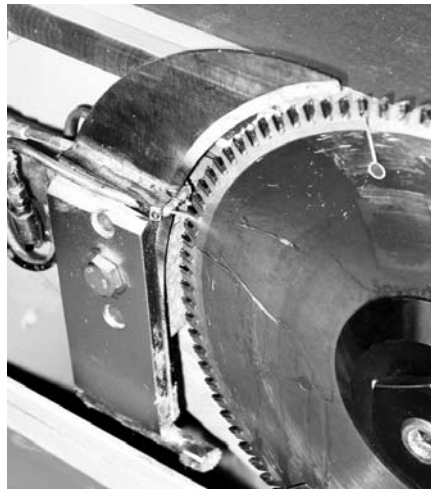

Fig. 5: Spray mist on circular saw blade

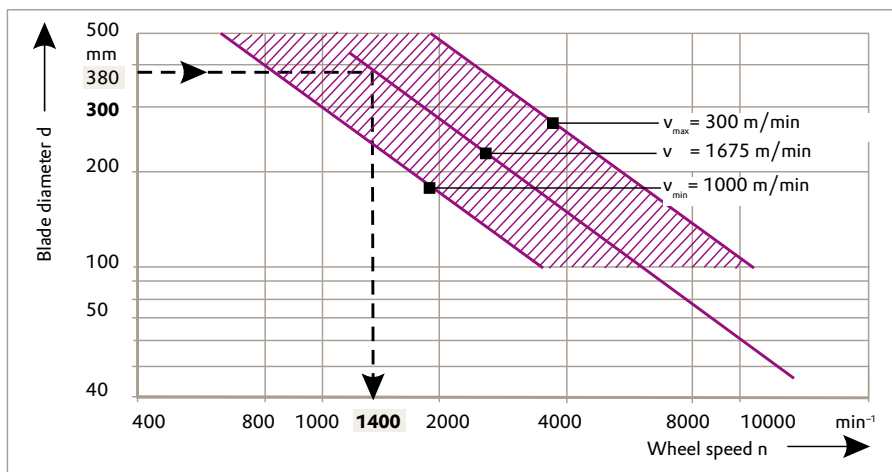

Fig. 6: Recommended cutting speeds, blade diameters, and wheel speeds for bandsawing of PLEXIGLAS®

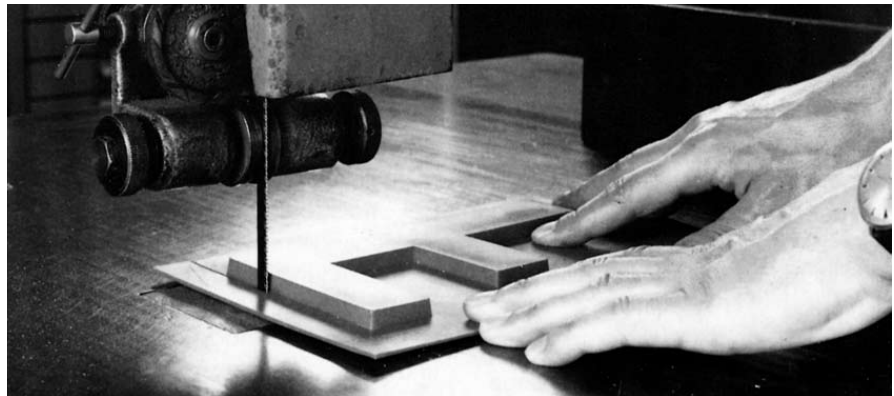

Fig. 7: Edge trimming with bandsaws

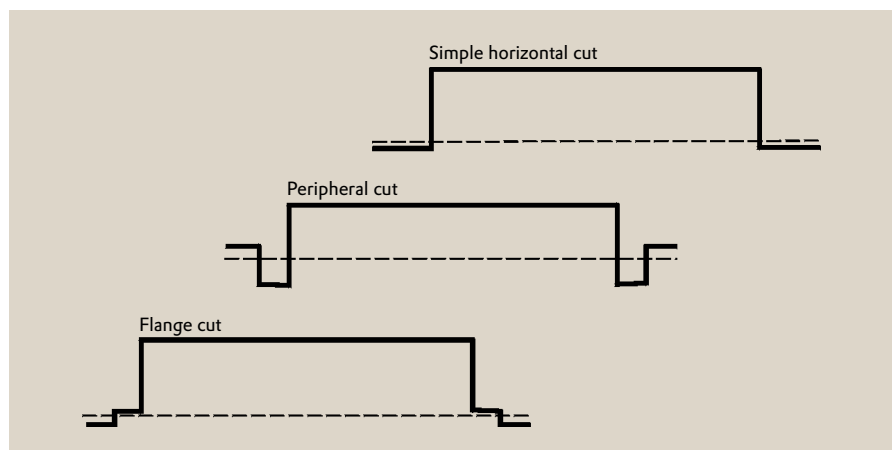

Fig. 8: Possible cuts with horizontal bandsaws

2 Cutting

2.3 Scrollsaws/ Fretsaws

For cutout work on thin stock with frequent changes in direction, scrollsaws with fretworking blades or spiral cutting wires can be used. The swarf produced during this operation should be blown off by means of compressed air. Slow feed rates and cutting speeds of less than 1500 m/min prevent overheating of the material. Particularly advantageous are machine tools which move not only up and down but also in a horizontal direction.

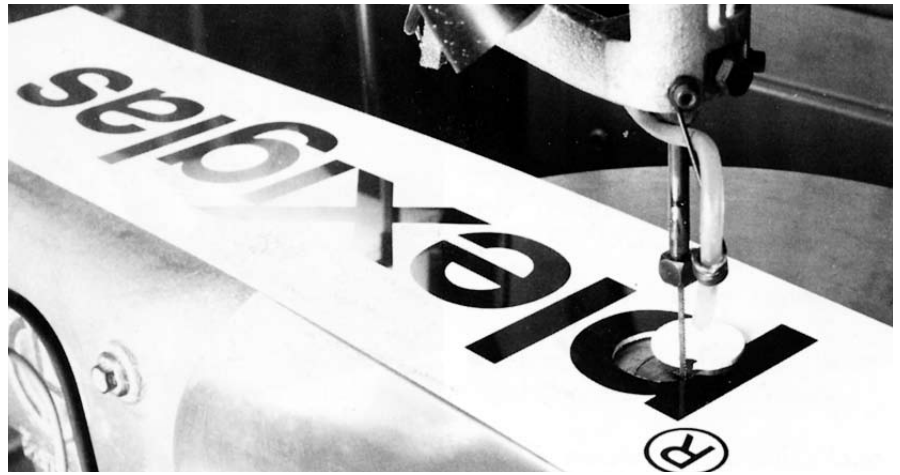

Fig. 9: Scrollsawing of PLEXIGLAS® logo

2.4 Jigsaws

Jigsaws have proven suitable for dovetailing and mortising. The cut edges, however, are fairly rough and may have to be smoothed. The jigsaw blade should be fine-toothed with a slight set. Blade packages must be labeled as being suitable for use on hard plastics.

The following hints must be observed for jigsawing:

- adjust stroke action to zero for sheets up to 4 mm thick, and to 1 or 2 for thicker sheets; select an average feed rate.
- set saw to a high cutting speed;
- always turn on saw before starting to cut;
- place shoe firmly on the masking film;
- cool PLEXIGLAS®, particularly PLEXIGLAS® XT from 3 mm thickness onwards, with water or compressed air.

When cutting recesses, holes should be predrilled at the corners to avoid notch effects and thus possible breakage of the workpiece.



Fig. 10: Jigsawing after predrilling

2.5 Handsaws

For DIY and artistic work, PLEXIGLAS® can be cut with fine-toothed handsaws like backsaws (dovetail and tenon saws), hacksaws, and scrollsaws. If the tools are handled carefully, good results will be achieved.

2.6 Die-Cutting and Guillotining

Prior to die-cutting or guillotining, PLEXIGLAS® XT must be heated to between 100 and 140 °C, PLEXIGLAS® GS to 150 °C. The cutting tools should have a temperature of 120 to 130 °C. The recommended maximum sheet thickness is 4 mm. Steel rule dies produce nearly rectangular cuts if the tool wedge angle is 20°.

When die-cutting or guillotining heated material, allow for expansion and contraction.

2.7 Scoring and Breaking

Sheets of PLEXIGLAS® up to 3 mm thick can be scored with a scribing knife along a ruler or a curve template with not too narrow radii, and then neatly broken. This method is popular among do-it-yourselfers, but also at building sites if no other tools are available. In contrast to sawing and routing, it generates little internal stress in the surfaces of fracture, which need not be annealed. The broken edges should be deburred by means of a scraper.

Impact-modified materials like PLEXIGLAS RESIST® are not suitable for scoring and breaking.

2.8 Laser Cutting

Normally, sheets of PLEXIGLAS® can be easily cut with CO₂ lasers. The glossy cut edges typically obtained on acrylics may vary in quality, depending on material grade, material thickness, and color. This should be tested beforehand and the laser adjusted accordingly.

CO₂ lasers normally have a power between 250 and 1000 watts. On the majority of lines, materials other than PLEXIGLAS® are also lased. Therefore, it is difficult to recommend a certain laser performance for individual applications, since this depends on several factors, such as the purity and water content of the laser gas, the gas throughput, condition of the IR optics, etc.

Tests have been performed on sheets of varying thickness and different degrees of edge gloss using 300 W to 700 W lasers.

Depending on laser power, feed rates have to be adjusted to the sheet thickness in order to achieve the desired shiny cut edges: thinner sheets call for higher feed rates, thicker sheets for lower ones. If feed is too slow, dull edges will be the result, if it is too fast, striation and gouges will appear. However, this phenomenon may also be the result of inaccurate focusing of the laser beam.

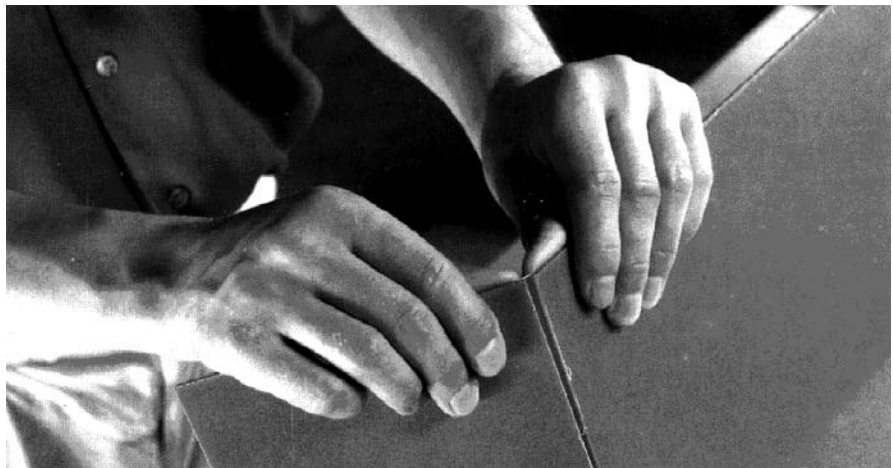
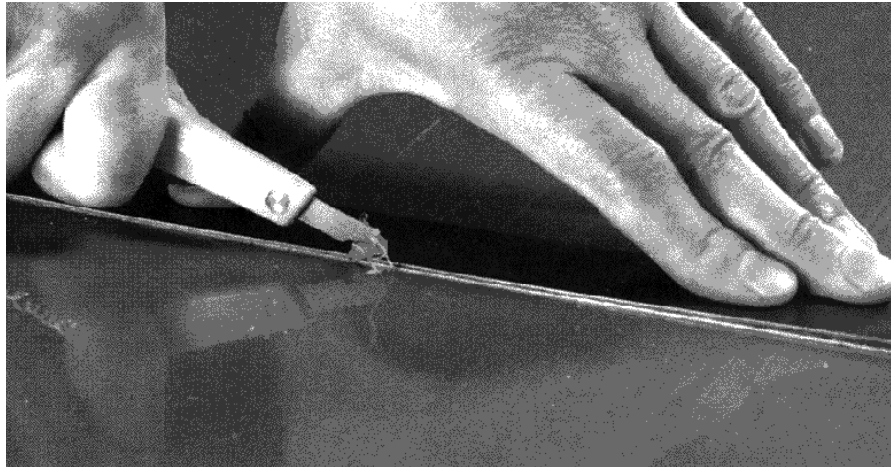

Fig. 11: Scoring and breaking

2 Drilling

The edges on sheets of increased thickness will always be slightly oblique. The laser beam should be focused on the center of the sheet thickness. If it impinges above or below this point, V-shaped or, on particularly thick sheets, concave cut edges will be obtained. In order to obtain edges as rectangular as possible, it is recommended to adjust the following focal lengths (Source: Messer Griesheim):

- up to 6 mm sheet thickness: 2 1/2" lens
- 6 to 15 mm sheet thickness: 5" lens
- over 15 mm sheet thickness: 10" lens.

Between 5" and 10" focal length, the laser optics have no influence on the appearance of the cut edge, whereas they do affect the angularity of the cut, along with the focal position and the sheet thickness.

In order to prevent smoke gas splashing back on the lens, minimal compressed air purge (with oil and water separator) at the laser head is usually sufficient.

At the same time, the vapors generated must be extracted in a suitable manner on the beam exit side, e.g. with slight suction or air purge as well.

In addition to the aforementioned air purge or vapor extraction, some systems are equipped with nozzles at the laser head for purging with inert gas, such as nitrogen, for example. This is not necessary for normal cuts, but it can be useful for precision parts.

Possible laser-beam flashback as a result of flat support material being used for the PLEXIGLAS® sheets might impair them optically and contaminate the lens. Grid supports can usually prevent this.

A speed- or power-controlled laser beam can improve the cutting result, for example at corners, angles, tips, etc.

A computer-controlled laser beam cuts even the most complex shapes. Appropriate systems also cut thermoformed parts three-dimensionally.

Stress generated in the immediate vicinity of cut edges may have to be relieved by subsequent annealing in order to eliminate the risk of crazing (see '8 Annealing').

2.9 Waterjet Cutting

Cutting plastics sheets with a waterjet is similar to cutting them by laser beam. The technique costs less, but does not permit the same high cutting speeds as the laser beam and fails to provide shiny cut edges.

There are two alternatives:

- cutting with a clear water jet
- cutting with an abrasive water jet.

Cutting with a water jet does not produce good results with acrylic, but can be performed on PLEXIGLAS® if abrasives are added to the water.

The cut surface then looks as if sanded. The requisite feed rate depends on the sheet thickness, the desired quality of the cut, and the abrasive grit. For example: the cutting speed for PLEXIGLAS® GS, 10 mm thick, is approximately 100 mm/min.

3 Drilling

Caution: Before using commercially available twist drills for metal on acrylic, their bits must be suitably reground (see 1.7 Tools).

3.1 Twist Drills

Twist drills cannot be used on PLEXIGLAS® unless the point angle is reduced from normally 120° to between 60 and 90°. **The rake angle must be ground down to between 4 and 0°.** If the drill is to work correctly, the principle is **to scrape rather than cut, so that chipping at the exit side of the hole is avoided (see Fig. 12).** The clearance angle should be at least 3°. If the drill holes are larger than approx. 8 mm diameter, the transverse cutting edge should be sharpened so as to reduce the contact pressure at the start of drilling. In order to rule out notch effects altogether, the drill holes should be slightly chamfered or countersunk.

Twist drills with a smaller helix angle ($\beta = 12$ to 16°) are advantageous for better chip removal, but they too have to be reground in the above-mentioned manner.

Grinding and operating data

PLEXIGLAS® GS und XT

Clearance angle α	3° to 8°
Rake angle γ	0° to 4°
Point angle σ	60° to 90°
Helix angle β	12° to 16°, usually 30°
Cutting speed v_c	10 to 60 m/min
Feed f	0.1 to 0.3 mm/U

From a material thickness of 5 mm onwards, use a cooling lubricant, or a drilling (oil in water) emulsion compatible with acrylic. When drilling deep holes it may be advisable to use exclusively drilling emulsions.

Fig. 13 illustrates the ideal drilling conditions: given a feed rate between 0.1 and 0.3 mm/rev. and a drill diameter of 25 mm, the most favorable speed is 510 rpm. Under these conditions, and using drilling emulsion, drill holes with almost transparent, silky matte walls are obtained. The surface quality can be further improved by treatment with the reamers known from metalworking.

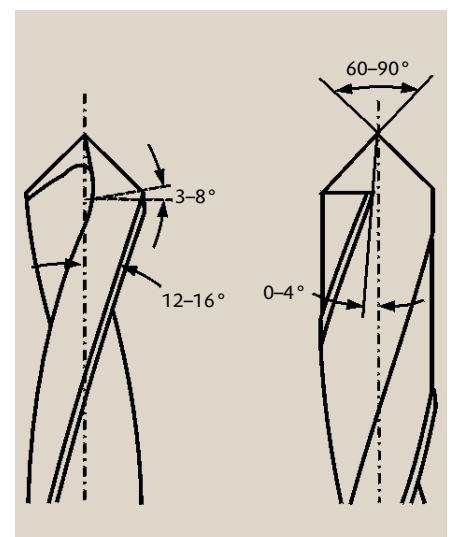

Fig. 12: Correct grinding of HSS drills for PLEXIGLAS® (cutting edge must scrape rather than cut!)

3.2 Special Drills and Countersinks

Special tools for PLEXIGLAS® should be used if, besides ordinary workshop treatment – say, on the building site – moldings or installed parts are drilled by hand. These tools are designed to prevent the material from fluttering or splitting.

Commonly used special drills or countersinks are:

(a) **step drill**

This one-edged drill does not leave any chatter marks and guarantees clean cylindrical bores. With each subsequent drilling step, the hole is simultaneously chamfered, thereby increasing the economy of the work process.

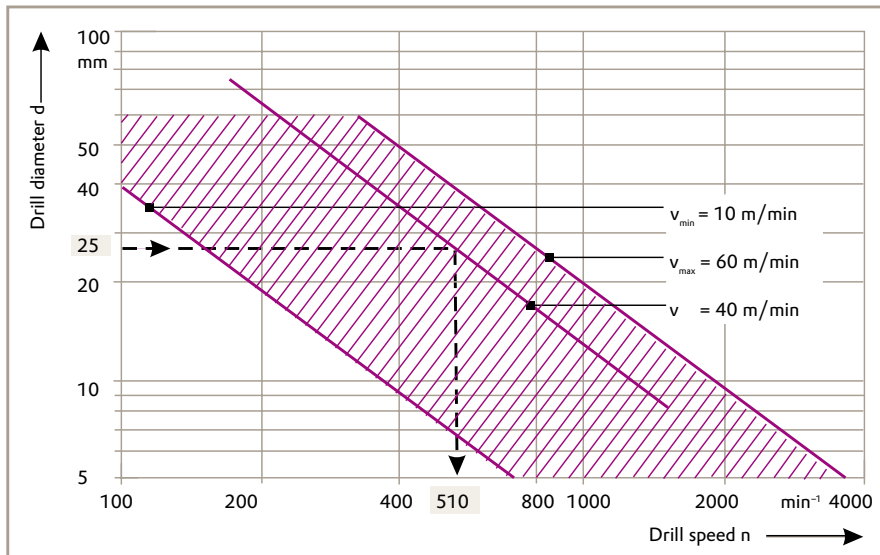

Fig. 13: Recommended cutting speeds, diameters, and rotational speeds for drilling PLEXIGLAS®

Our pictures in Fig. 14 illustrate the influence of drill rotational or cutting speed and feed on the quality of the work (example: PLEXIGLAS® GS):

(Top) Speed and/or feed rate too high: crumbly chip, uneven cut

(Center) Speed and/or feed rate too slow: overheating, signs of decomposition in the drill hole, molten chip.

(Bottom) Optimal speed and correct feed: smooth surface; smooth, continuous chip flow.

Thin sheets should be clamped onto a flat, solid support for drilling in order to prevent chipping at their bottom surface. Start all drilling work cautiously at a slow feed rate. As soon as all cutting edges have taken hold of the material, the feed rate can be increased. Just before the bit exits the bottom surface, slow the feed again.

When drilling thick-walled material, deep holes or blind holes by hand, the tool should be lifted several times to avoid overheating. Holes in turned parts or long workpieces are best drilled on lathes.

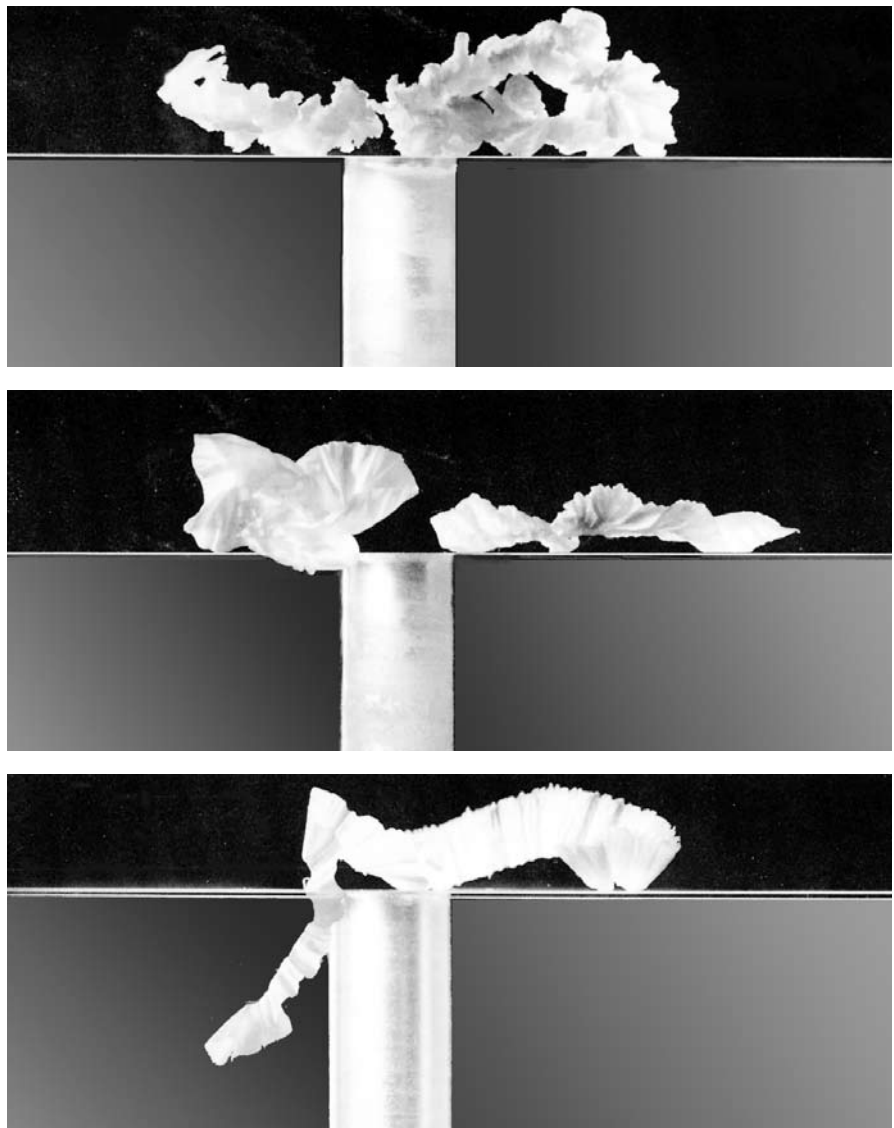

Fig. 14: Different types of chip

3 Drilling

(b) conical drill

The drill holes are slightly conical, but there is no chipping on the exit side of the hole. Triple-edge design.

(c) special countersink

One-edged; specially suitable for deburring existing holes; good chip flow due to oblique drilling; no chatter marks.

(d) cutter drill

Very simple to use also for long holes.

(e) countersink

This multiple-edged tool is recommended for deburring, chamfering and counterboring.

Care must be taken that the bits of any special drills are in perfect condition.

The rotational speeds of these tools usually differ noticeably from those of twist drills. Types (a), (b), (c), and (e) are used at **low** speeds, adjusted to the material. Tool (d), on the other hand, is often used at over 10,000 rpm, similarly to milling cutters.

3.3 Hole Cutting

Large holes in thin sheets of PLEXIGLAS® can be produced using the following tools:

- circle cutter (Fig. 16)
- "Slugger" cutter or hole saw (Fig. 17)
- endmill (Fig. 18) in milling machine or comparable machine with a pivoting clamping table

Especially for hole cutting, the cutting speed must be adjusted to the circumstances. The commercially available tools for metal are used. When PLEXIGLAS® XT is machined with "Slugger" cutters or hole saws, water cooling is recommended.

Circle cutters used for PLEXIGLAS® require a rake angle of 0°. As in drilling, thin sheets should also be clamped onto a solid, level support for hole cutting in order to obtain an equally clean bottom surface of the hole.

For holes up to approx. 60 mm in diameter, use a **"Slugger" cutter** or **hole saw**,

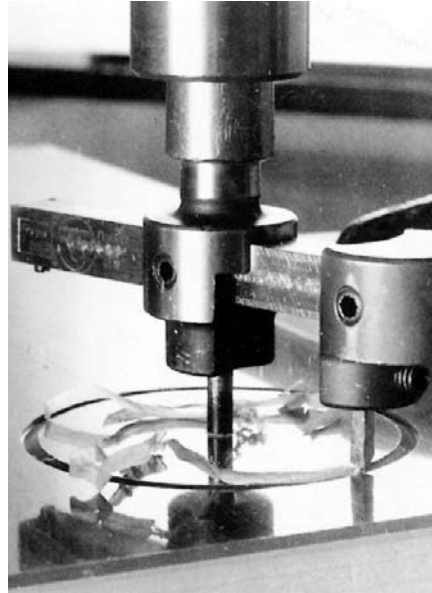

Fig. 16: Circle cutter

which have the advantage over circle cutters that they can be combined with a hand drill.

A center drill is normally used to predrill hole centers for reasons of stabilization.

Endmills should be run at high speeds (from approx. 10,000 rpm onwards). Simpler tools may be used if they are equipped with a (hand-controlled) milling

motor. Given a plane material, large holes can be obtained by milling, or – since center drilling is not required – round discs can be cut out, provided the machines are equipped with rotary worktables. The sheet is either clamped to the table mechanically, or is sucked against it under vacuum. In both cases it must be firmly held to avoid fluttering or splitting.

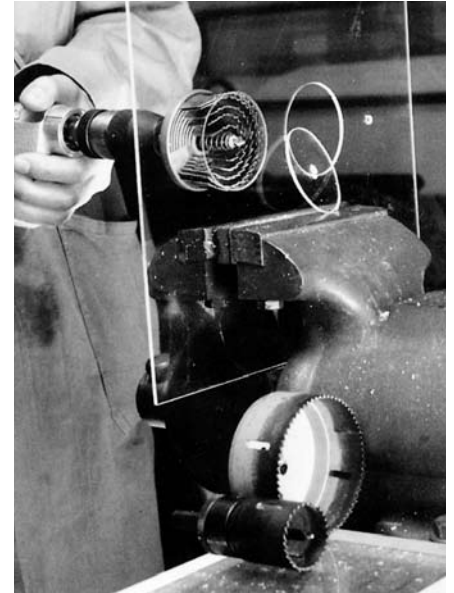

Fig. 17: "Slugger" cutter and hole saw

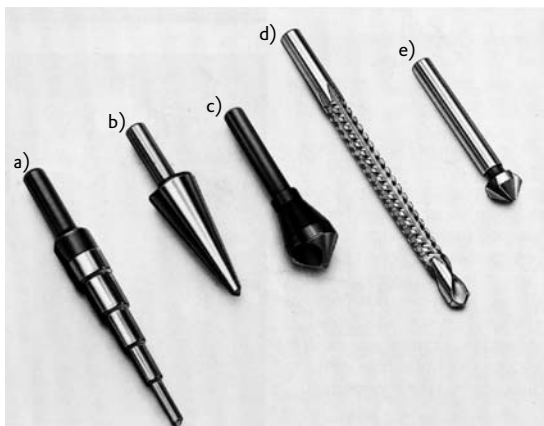

Fig. 15: Various special drills (for details see text)

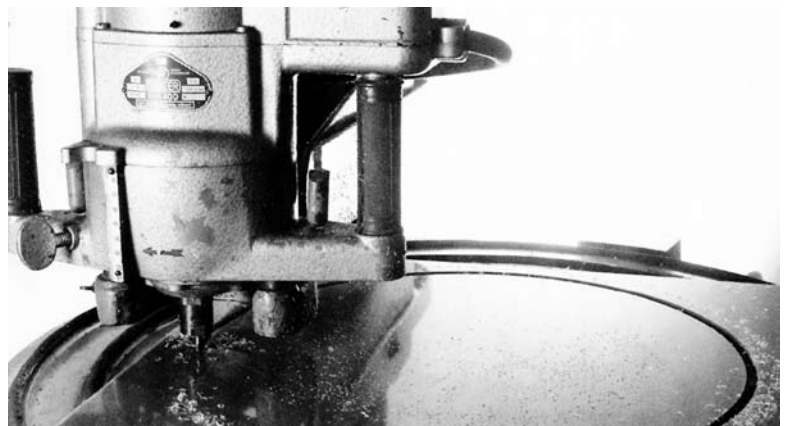

Fig. 18 Endmill

3.4 Threadcutting

All commercially available taps and dies can be used for cutting inside or outside threads in PLEXIGLAS®. **The use of cutting lubricants compatible with acrylics is recommended.**

During subsequent screw union, great care must be taken that there is no oil film on the metal screws or that the oil is compatible with plastics. Plastic screws, e. g. made from polyamide, are recommended for inside threads.

Threadcutting in plastics always involves the risk of breakage due to notch effects. This applies in particular to extruded acrylic, and should therefore be avoided with PLEXIGLAS® XT. Threaded fastening should be the last choice after bonding, clamping, or screw union by way of a throughhole.

The clearance hole should be drilled approx. 0.1 mm larger in diameter than in the case of steel. In order to reduce thread wear to a minimum, during repair work or to increase the stability of the equipment part, it is advantageous to reinforce the inside thread by means of a threaded insert made of metal, which can be installed in various ways.

4 Routing

The routing technique is used for PLEXIGLAS® where sawn edges, die cuts or shearing cuts have to be treated, contours produced and molded parts trimmed.

Two advantages over sawing become particularly obvious here:

Almost any desired contour can be cut out of the sheet material with utmost precision and without the risk of chipping on the underside of the cut. Moreover, the distinctly better quality of the cuts reduces the outlay for aftertreatment.

All commercially available routing machines can be used, from the simple hand router to computerized numerical control machines. Although some machines are provided with multiple-part cylindrical cutters, single- or double-fluted endmills with good chip removal should be used for small diameters in order to achieve high cutting speeds and thus clean cuts. If multiple-fluted mills are used at high speeds, the teeth are likely to become clogged. In the case of single-fluted cutters, however, it is important to balance

the chuck carefully by means of adjusting screws. Failure to do so may result in imbalance, causing chatter marks on the workpiece and/or damage to the machine.

Fig. 19 shows that the best routing results are achieved with a trimming cutter measuring, say, 8 mm in diameter and rotating at 11,000 rpm, or else with a diamond milling head of diameter 90 mm and a speed of 15,000 rpm. The respective cutting speeds are then still within the recommended range.

Although the choice of milling cutter depends on the task to be performed, certain prerequisites have to be met in all cases:

Grinding and operating data

PLEXIGLAS® GS and XT

Clearance angle α	2° to 10°
Rake angle γ	0° to 5°
Cutting speed v_c	200 to 4500 m/min
Feed f	to 0.5 mm/rev.
Cutting depth a	up 6 mm

Just as with sawing, routing results also depend on the correct cutting edge geometry. The following router types provide immaculate cut edges during **trimming and slot milling** of PLEXIGLAS® XT, but also of PLEXIGLAS® GS.

This double-flute, solid carbide milling cutter (Fig. 22, (a) and (b)) is designed for edge trimming:

- the **large rake angle** for good chip flow and for slotting;
- a **cutting edge extending to the center of the cutter** facilitates "immersion in the material."

Milling cutters **without twist**, e. g. PLECUT (Fig. 22, (c)), have proved to be ideally suited for **trimming stacks of sheets** (with the PE protective surface masking film left in place). With this type of milling cutter, the individual sheets can be prevented from separating.

Normally, cooling is not necessary for routing acrylic. However, it is recommended when using multiple-fluted cutters with fairly large diameters and often indispensable for cylindrical cutters. Choose cooling lubricants that are compatible with acrylic.

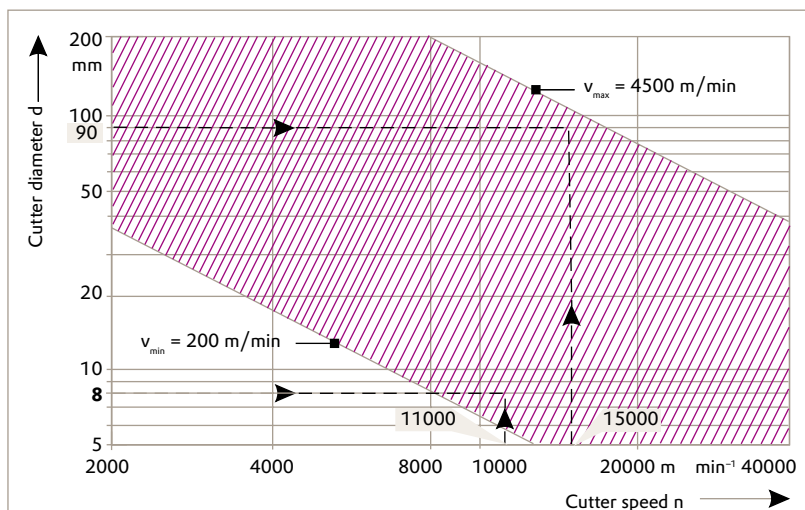

Fig. 19: Recommended cutting speeds, diameters, and rotational speeds for routing PLEXIGLAS®.

4 Routing

For many fabricating techniques, the sheet edges have to be beveled or chamfered, such as for bonding with polymerization adhesives. This can often be done more effectively with a milling cutter than with an arbor-mounted circular saw. Chamfering by milling cutter is also possible with tubes (see Fig. 20). After bonding or forming, there are often beads or flanges to be reduced to the same width or to be eliminated altogether. Again, milling cutters are the tools of choice, together with suitable spacer rolls, such as roller bearings, along which the workpiece is guided (see Fig. 21).

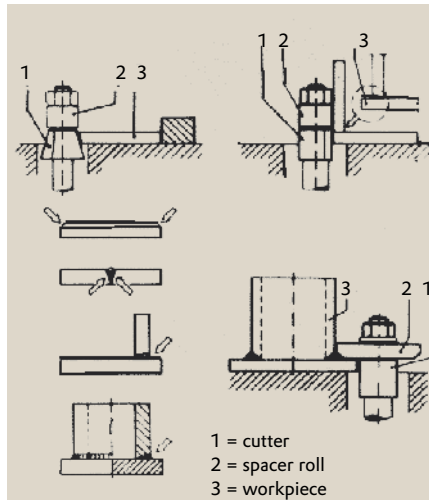

Fig. 20: Chamfering of sheets

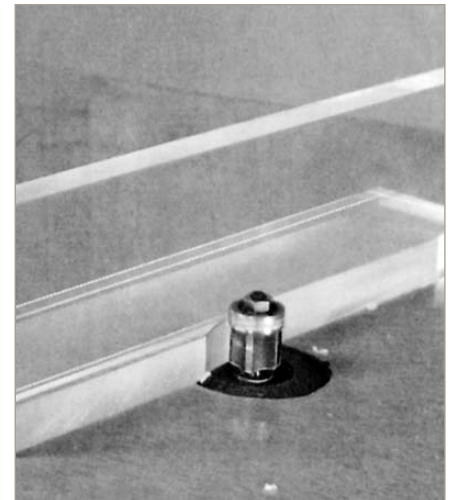

Fig. 21: Milling down beads of adhesive

Routing with diamond-tipped tools is recommended where polished high-gloss surfaces are to be obtained (see '7.2 Polishing').

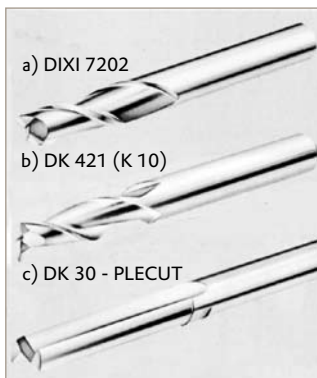

Fig. 22: Optimal routing cutters for trimming and slotting



Fig. 24: Routing of PLEXIGLAS® with shell endmill; various other cutter types: (a) double-fluted cutter; (b) cylindrical cutter; (c) diamond cutter

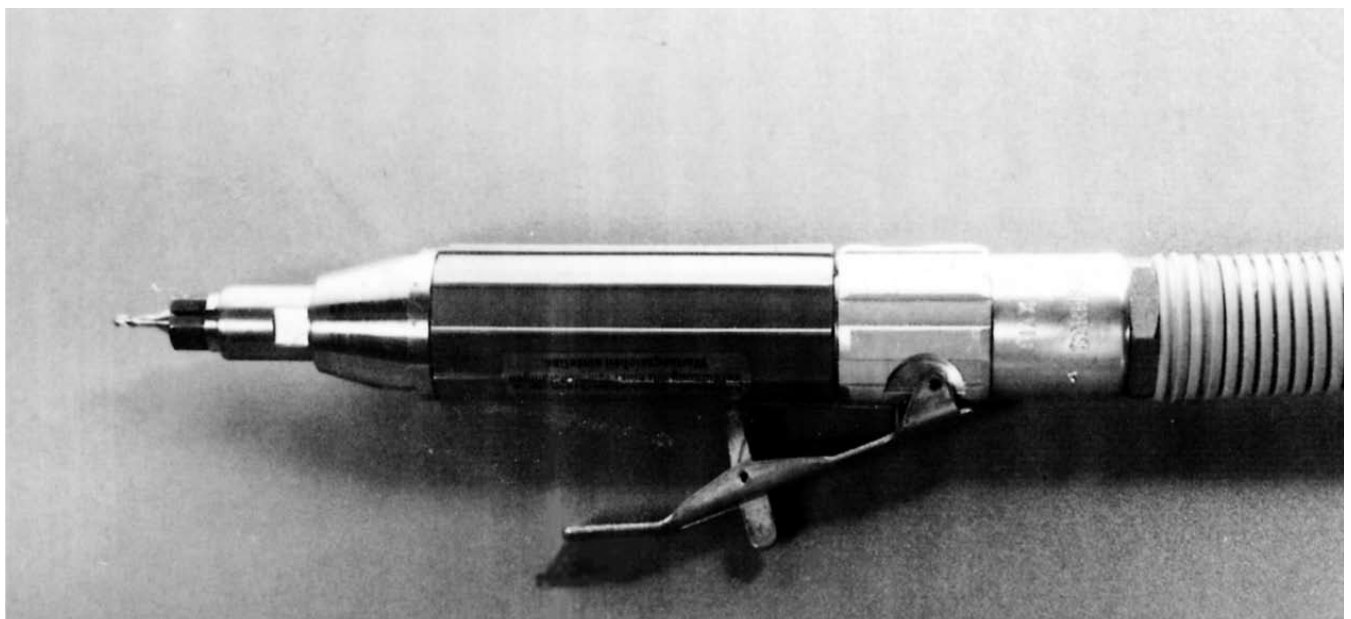
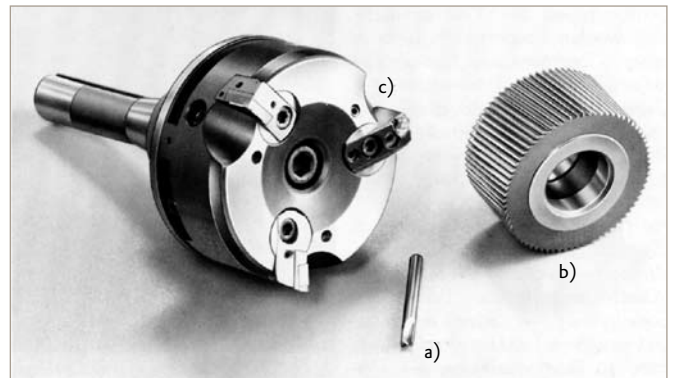

Fig. 23: Pneumatically driven router spindle

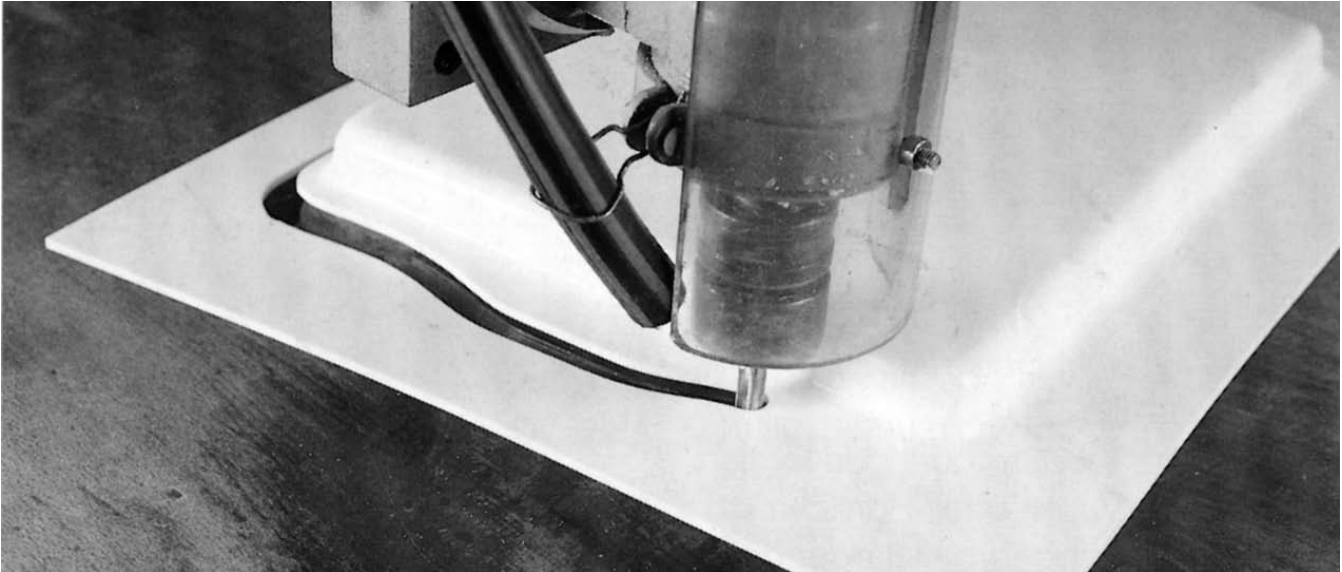

Fig. 25: Trimming of a molded part by template router

4.1 Template Routing

For rounding corners and cutting out circles, letters, and contours of any kind, overhead routers or inverted routers are used. In the case of overhead routing, the template lies under the workpiece, and the holding devices (stop, suction hole for vacuum, etc.) are also arranged below it. The template is either guided along a pin or is mounted on a pivot.

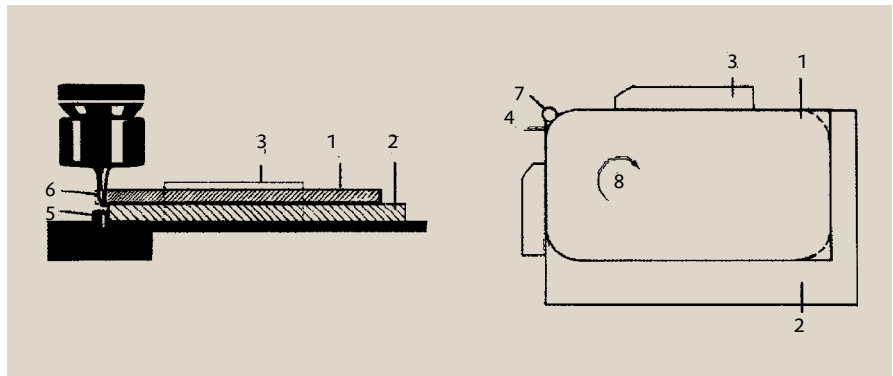

Fig. 26: Principle of overhead template routing (rounding of corners: 1 = workpiece, 2 = jig, 3 = stop, 4 = template, 5 = pilot pin, 6 = cutter, 7 = cutter working range, 8 = feed)

4.2 Engraving

Industrial or artistic engraving work is usually performed with engraving cutters, overhead or inverted template routers, or with single-fluted graving bits, which are either controlled electronically or are piloted around a pattern by hand.

Electrically driven flexible shafts, pneumatically driven routing or grinding tools, and high-speed electronic diamond gravers are suitable for artistic engraving work.



Fig. 27: Engraving with CNC portal-type machine; single-fluted graving bit.

5 Turning

5 Turning

The lathes commonly used for metal working are also employed for turning PLEXIGLAS®. The **cutting speeds** should be as high as possible, depending on the workpiece and the type of lathe. **The rule of thumb is ten times the cutting speed for steel.** The prerequisite for good results is a perfectly ground turning tool.

As in drilling, a continuous chip flow is proof of the correct tool grinding angle, feed rate and cutting speed as well as optimal coordination of these parameters with one another.

In all cases the radii of the tool bits should be at least 0.5 mm. Fine-finished surfaces are obtained with a round-nosed tool, at high cutting speeds, low feed rates, and minimal cutting depths. This surface can then be polished without previous grinding.

Fig. 28 shows that favorable machining conditions for a workpiece measuring, say, 40 mm across exist if a cutting speed is selected between the typical lathe rotational speeds of 224 to 1,250 rpm.

Carbide-tipped turning tools are suitable for roughing work, but the cutting depth should not exceed 6 mm. For subsequent fine finishing, HSS tools are normally used. Yet the surface quality of the workpiece depends not only on the tools but also on the cutting speed and the feed rate.

A drilling emulsion or cutting oil compatible with acrylic may be used for cooling.

High-gloss surfaces of superior quality are obtained using carefully polished diamond tools on chatter-free precision lathes. The cutting speed may be higher than when using other tools for turning. Cooling cannot be recommended for precision work, however, because it will cause optical flaws.

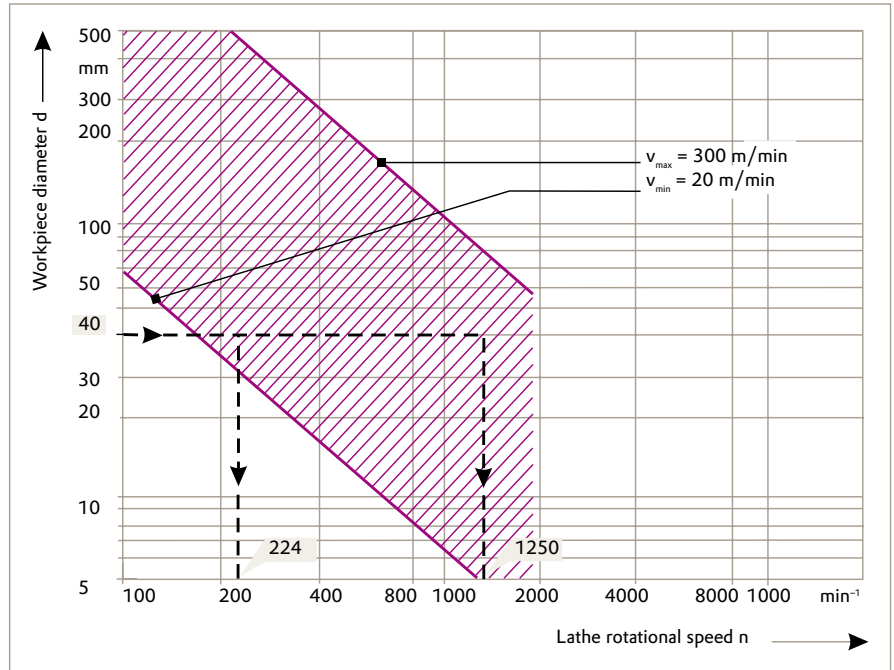

Fig. 28: Recommended cutting speeds, workpiece diameters, and lathe rotational speeds for turning PLEXIGLAS®

Grinding and operating data

PLEXIGLAS® GS and XT

Clearance angle α	5° to 10°
Rake angle γ	0° to -4°
Cutting edge angle κ	ca. 45°
Cutting speed v_c	20 to 300 m/min
Feed f	0.1 to 0.5 mm/rev.
Cutting depth a	up 6 mm

The lathe is a very economical tool for cutting discs out of sheet material (Fig. 29a and Fig. 30): clamp a stack of blanks between chuck and tailstock and reduce to the desired diameter in several steps. The tool width and cutting edge angle depend on the thickness of the discs. For thin discs, broad tools with small cutting edge angles should be used. Turning is also a highly suitable technique for cutting off molded edges (Fig. 34).

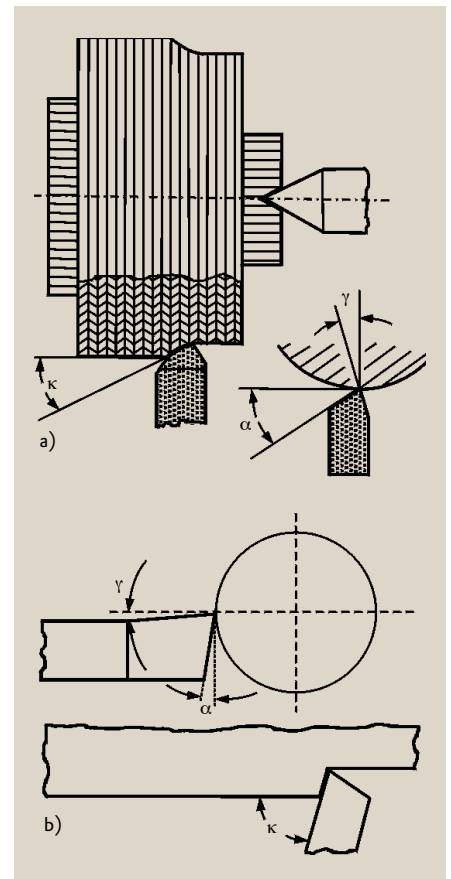

Fig. 29: Angles defined on turning tools

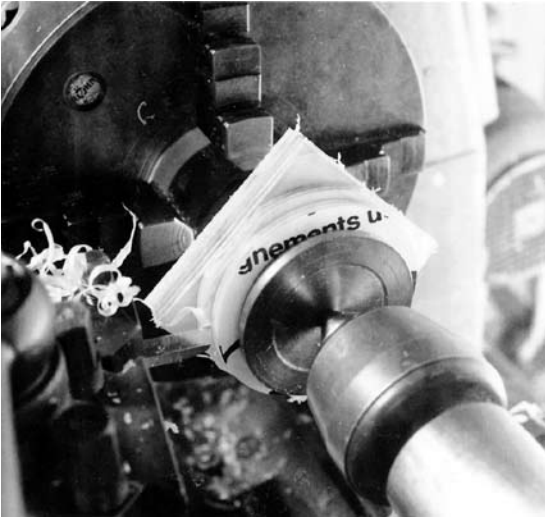

Fig. 30: Turning blanks into round discs between chuck and tailstock

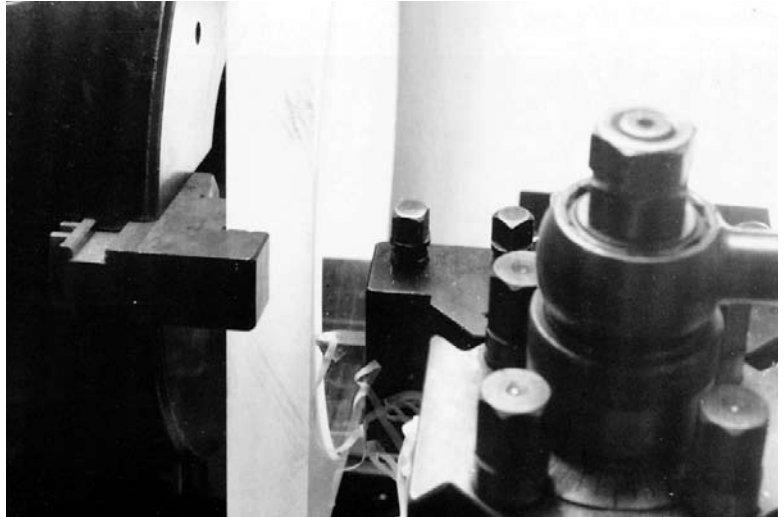

Fig. 31: Turning off a block of PLEXIGLAS® GS

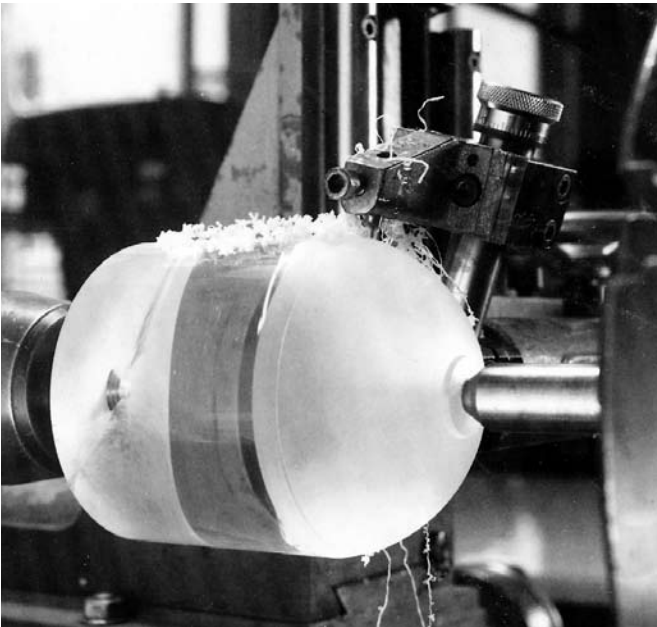

Fig. 32: Ball shape made from PLEXIGLAS® GS round rod using a ball turning fixture

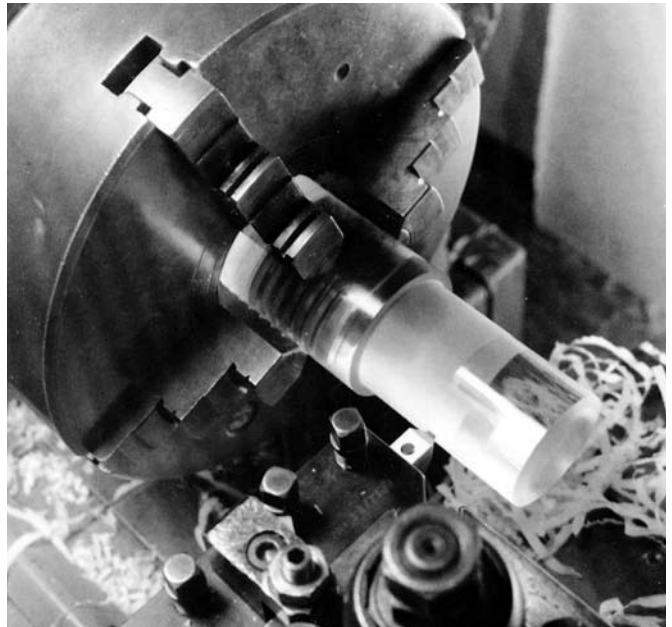

Fig. 33: Workpiece pretreated with HSS tool and then diamond-polished

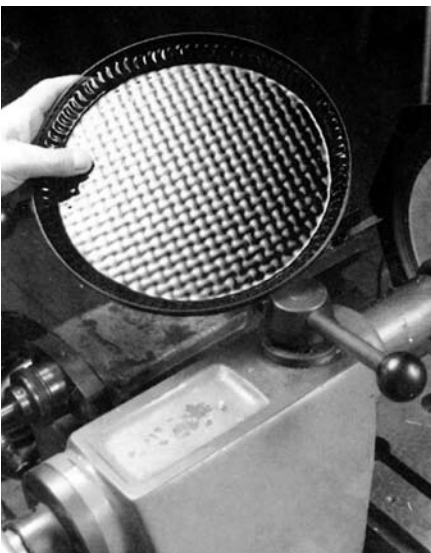

Fig. 34: Cutting off the molded edge

6 Filing - Deburring - Planing

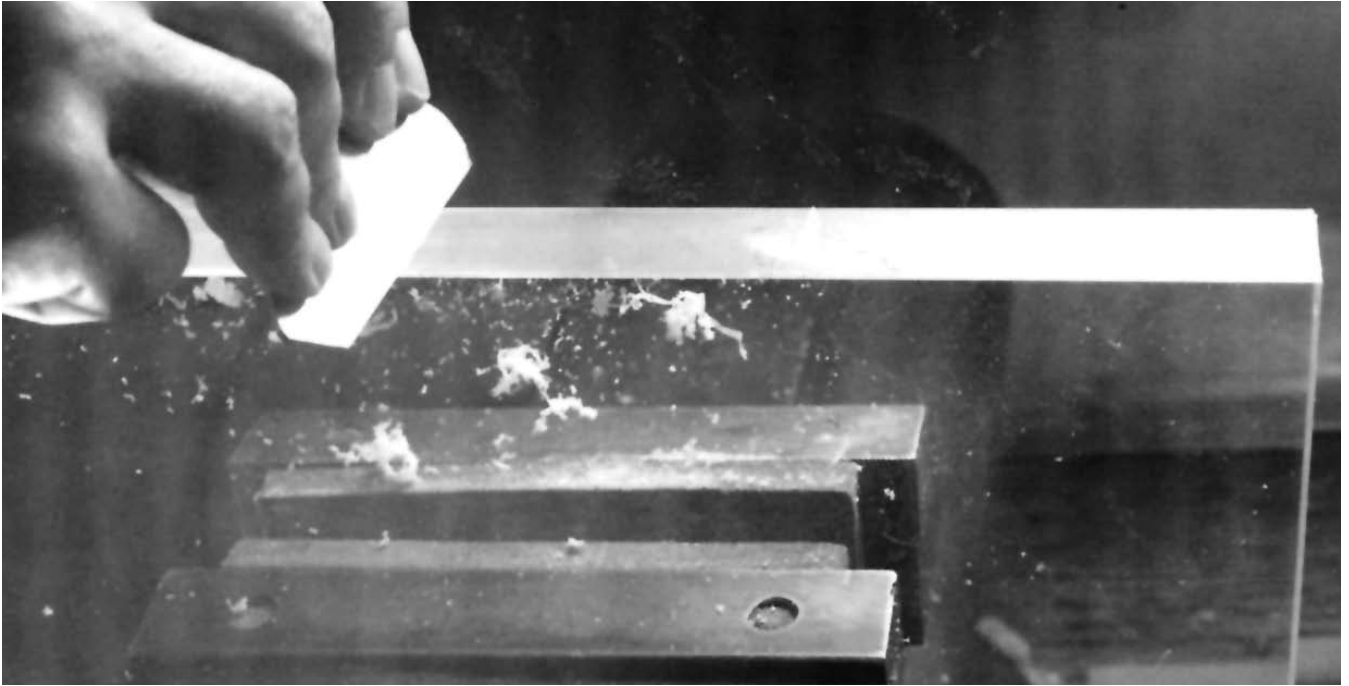

Fig. 35: Deburring PLEXIGLAS® with a scraper

6 Filing - Deburring - Planing

PLEXIGLAS® can be worked with all conventional files and relatively fine rasps. These should not have been used on metal before. The choice of tool depends on the work to be performed, such as roughing or fine finishing.

For deburring sawed, milled or turned parts, triangular files or scrapers are also used, especially where thin edges need to be aftertreated.

PLEXIGLAS® can also be smoothed on surface planing machines as used for wood.



Fig. 36: Smoothing the edges with a surface planer

7 Sanding and Polishing

By sanding and subsequent polishing parts of PLEXIGLAS® whose **cut edges** have become rough and dull during machining can be restored to their high-gloss transparency.

Even heavily scratched and scuffed **areas** can be restored. **Partial polishing, especially after sanding, is accompanied by material wear and remains optically visible.**

Products with coated surfaces, such as 'NO DROP', 'ALLTOP', 'HEATSTOP', 'MIRROR', must not be sanded or polished, because this would damage the surface coating.

7.1 Sanding

Wet sanding is recommended in all cases in order to avoid generating thermal stress in the workpiece and to prevent logging of the abrasive surfaces.

The choice of abrasive grit depends on the depth of the tool marks or scratches: the deeper the marks, the coarser the grit. Sanding is normally performed in several steps using increasingly fine sandpaper. It is advisable to work in three steps:

1. coarse, 60 grit
2. medium, 220 grit
3. fine, grits 400 to 600.

All traces of the preceding sanding operation must be removed. Sanding can be done by hand using abrasive paper or a coated sanding block, both of which should be passed over the workpiece with circular movements. For **mechanical sanding**, e.g. by means of rotating abrasive discs, orbital sanders, or belt sanders (belt speed ca 10 m/sec), the workpiece should be moved lightly and not be pressed on too long and with too much force (despite **wet sanding**), since the resulting frictional heat may cause stress buildup and surface damage.

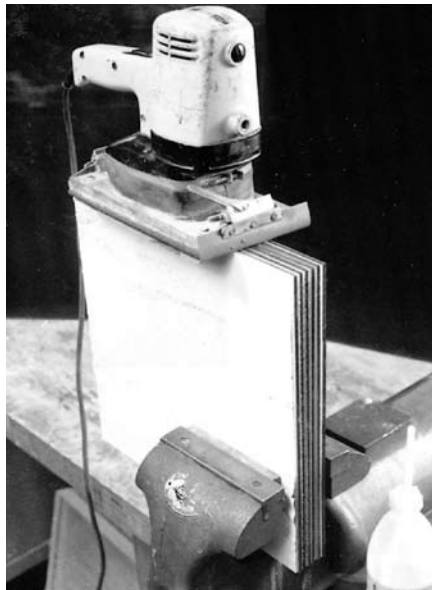

Fig. 37: Sanding the edge of a stack of blanks using an orbital sander

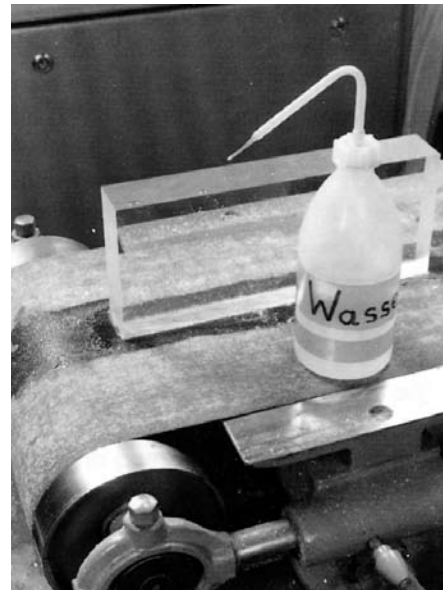

Fig. 38: Wet sanding on a belt sanding machine

Wet treatment with fine steel wool, e.g. type 00, is recommended for turned parts or non-level surfaces.

Mechanical roughing of the surface by **sanding** (before polishing) or **dulling** by sandblasting causes the surfaces to pick up dirt more easily and show fingerprints. (Details are provided in our 'Guidelines for Workshop Practice, Surface Treatment, Chapter 5').

7.2 Polishing

PLEXIGLAS® GS and PLEXIGLAS® XT can be edge-polished without any problem. Polishing of the surface – as mentioned previously – is less advisable. Three methods are available for PLEXIGLAS® GS and XT:

- polishing by belt, buffing wheel, or cloth
- flame polishing
- diamond polishing.

Normally, waxes and creams are used for polishing, but ordinary car polish also serves the purpose. **Immediately after treatment, all traces of the polishing agents used must be carefully removed or rinsed off with water.** Therefore, it is advantageous to use water-soluble pastes, such as the polishing cream for acrylic offered by BURNUS (Acrylglas POLIER & REPAIR Paste).

Since the media employed for polishing – **felt buffing belt, cloth buffing wheel, or glove lining fabric** – are very soft, the surface to be polished must have a fine finish. Otherwise the surface, although becoming glossy, will show polishing marks and scratches. Edges can be fine-finished with a scraper if they are subsequently polished on a felt belt.

As for sanding, the recommendation is: **Do not press the material against the polishing medium either too long or with too much force.**

This is the only way to avoid excessive buildup of frictional heat and thus stress generation and surface damage. In individual cases it may be necessary to anneal the polished material for stress relief (see '8 Annealing').

7 Sanding and Polishing



Fig. 39: Polishing against a felt belt



Fig. 40: Polishing against a cloth buffing wheel

Normally, polishing is performed by means of a moving felt belt or a rotating cloth buffing wheel in combination with special polishing waxes. The brilliance of the surface can be further increased by manual aftertreatment with a very soft, non-linting cloth (glove lining fabric) or with cotton wool and polishing liquid.

Edges and small parts are preferably polished on **felt buffing belts**, where they are easier to hold or guide than against the larger rotating buffing wheels. The workpiece is to describe circular movements whilst being polished so that it cannot be damaged due to unevenness of the belt or buffing wheel. The felt belt should travel at a speed of approx. 20 m/sec, i.e. twice as fast as for sanding.

Automatic polishing machines are recommended for long production runs where it is important to produce sharp edges and corners, such as for picture frame cubes.

Cloth buffing wheels are particularly suited for polishing large and curved areas. The rotating cloth package consists of gray cotton and/or flannel, with the plies loosely arranged in order to dissipate frictional heat by fanning. Before starting to polish, apply some wax to the rotating wheel, which should always be free from old, hardened wax. An old hacksaw blade can be used to remove any such residues. The peripheral speed of the cloth buffing wheel is between 20 and 40 m/sec.

Another method for final treatment of cut edges on PLEXIGLAS® GS and PLEXIGLAS® XT is **flame polishing**. Although this dispenses with the need for fine-finishing as an additional work step, the edges must be free from residues like adhering swarf or perspiration from the hand. Normally, the marks of the preceding sawing or routing operation are still visible after flame polishing. Therefore, this more economical polishing method

(compared with the buffing wheel) will only be utilized where the polishing result is not overly important, as with the most frequently used clear, thin sheets. Thicker sheets can normally not be flame-polished since they will not tolerate the excessive surface stress built up during treatment. The same applies to colored material, where colorants or pigments reduce the gloss even more.

Unless flame polishing is skillfully performed, it involves the risk of "flashover," i.e. of the flame jumping onto the workpiece surface behind the cut edge, generating thermal stress in the material. This stress may cause crazing during further treatment or in subsequent use, e.g. when the material comes into contact with adhesives, paint thinners, or cleaning agents. To eliminate this risk, annealing must be performed in specific cases (see '8 Annealing').

There are semi-automatic flame polishers for straight edges of plane sheets of varying length. They feed the flame with an acetylene / oxygen mixture. The same good polishing results cannot be produced with acetylene / compressed air mixtures.

The burner and its tip may have to be adapted to the respective task in a preliminary test.

For manual flame polishing of curved edges on finished parts or of the inside of drill holes, for example, desktop devices are used whose flame is produced by a mixture of hydrogen and oxygen.

If PLEXIGLAS® is **diamond-polished**, there is no need for previous fine-finishing. Cutting and polishing are done in one step. Milling cutter heads with at least two diamond cutting points or diamond-tipped turning tools are used. Good chip removal is important. Each tool should be reserved for one material group, e.g. just for PLEXIGLAS®.

It is essential to use only high-quality precision tools and machines into which the workpiece can be clamped or in which it can be guided. The manufacturer alone is responsible for grinding and regrinding of the tool angles and for adjusting the cutting angle of the diamond cutting points. The machine must operate vibration-free in order to avoid chatter marks on the workpiece. These requirements are met by commercially available diamond polishing and milling machines.

Diamond polishing and milling machines can be run over prolonged periods of time and are therefore specially recommended for serial manufacture. The sharp edges they produce are best deburred with a scraper.

Barrel polishing or tumbling may be the method of choice for small parts obtained from PLEXIGLAS® by mechanical means: The parts are filled into a barrel polishing unit, to which abrasive powders and specially shaped pieces of wood are added as process media. After normally three work steps – fine-sanding (6 to 24 hrs.), polishing (ca 16 hrs.), burnishing (ca 12 hrs.) – the PLEXIGLAS® parts have acquired a high gloss.

Polishing of PLEXIGLAS®

Method	'Classic': (wet sanding + buffing wheel/ felt belt)	Flame polishing	Diamond polishing and milling	Care polishing (with cream)
Surface quality	excellent	moderate	good to excellent	excellent
Stress level	average	very high	average	low
Time consumption	high to very high	low	low	low to high
Investment	average	high	very high	low



Fig. 41: Diamond polishing

8 Annealing

Annealing means that plastics parts are first heated up and then cooled down slowly.

Plastics withstand considerable tensile stress as long as they are not exposed to corrosive media at the same time.

Tensile stress may be caused, for example, by:

- machining operations like sawing, milling, turning and sanding
- thermoforming, especially line bending
- irregular heating
- shrinkage of adhesives
- deformation during fastening (clamping, drilling, screw union)
- shrinkage after localized overheating due to incorrectly ground tools or polishing
- impeded thermal expansion
- internal stress in PLEXIGLAS® XT, especially tubes, due to manufacturing technique
- external load.

If corrosive media are also present – for example, solvents and thinners during bonding, printing or painting, monomer vapors during laser cutting or flame polishing, plasticizers from PVC insulation material, sealants, films and aggressive cleaning agents – **crazing** may be the result, with the parts becoming unfit for use, even though the same media do not cause damage to stress-free parts. **Therefore, the simultaneous presence of tensile stress and corrosive media must be prevented.**

Since it is impossible to rule out in advance that the material will be exposed to harmful substances in use, any tensile stress is to be eliminated by **'stress-relieving annealing.'** To this end, the PLEXIGLAS® parts are heated in suitable ovens to temperatures below softening point, within a period of time depending on thickness. Thereafter they are cooled down slowly. Too rapid cooling provides a cold, stiff exterior skin and generates more tensile stress since the material continues to shrink inside during cooling.

The following annealing conditions apply:

Temperatures

- PLEXIGLAS® GS: 80 °C (unformed parts up to 100 °C)
- PLEXIGLAS® XT: 70 to 80 °C (unformed parts up to 85 °C)

Annealing time

- PLEXIGLAS® GS and PLEXIGLAS® XT: the material thickness in mm divided by 3 is the annealing time in hours, but the minimum is 2 hours.

Cooling

- The cooling time in the oven in hours is the material thickness of PLEXIGLAS® in mm divided by 4. The cooling rate must not exceed 15 °C per hour.
- The PLEXIGLAS® temperature on removal from the oven must not exceed 60 °C.

9 Cleaning and Care

Only clear water is needed to clean and preserve PLEXIGLAS®. If the dirt pickup is more pronounced, the water should be warm and contain a mild household detergent. **Dry rubbing must be avoided at all cost.** Before drying the material – e.g. with a sponge, chammy, or glove lining fabric – care must be taken that all dirt particles have been removed.

Especially after intense rubbing, plastics become statically charged, whereupon they may attract dust. For this reason they should be treated with a product like “Antistatischer Kunststoff-Reiniger + Pfleger (AKU)” by BURNUS, which is sprayed onto lightly soiled surfaces directly, or else after thorough cleaning, and spread with a soft cloth without wiping the material dry. The dust-repellent effect lasts for a good while.

Windows and other glazing areas can be cleaned by means of a high-pressure spray-cleaning unit, with the addition of some dishwashing liquid if necessary.



Fig. 42: Cleaning agents

® = registered trademark

PLEXIGLAS,
PLEXIGLAS ALLTOP,
PLEXIGLAS FREE FLOW,
PLEXIGLAS HEATSTOP,
PLEXIGLAS RESIST,
PLEXIGLAS SATINICE,
PLEXIGLAS SOUNDSTOP,
ACRIFIX,
are registered trademarks of Evonik Röhm GmbH,
Darmstadt, Germany.

Certified to DIN EN ISO 9001 (Quality)
and DIN EN ISO 14001 (Environment)

This information and all further technical advice is based on our present knowledge and experience. However, it implies no liability or other legal responsibility on our part, also with regard to existing third party intellectual property rights, especially patent rights. In particular, no warranty, whether express or implied, or guarantee of product properties in the legal sense is intended or implied. We reserve the right to make any changes according to technological progress or further developments. The customer is not released from the obligation to conduct careful inspection and testing of incoming goods. Performance of the product described herein should be verified by testing, which should be carried out only by qualified experts in the sole responsibility of a customer. Reference to trade names used by other companies is neither a recommendation, nor does it imply that similar products could not be used.

Ref-No. 311-1 June 2009
10/0609/09718 (en)



Business Unit
Performance Polymers

Evonik Röhm GmbH
Kirschenallee
64293 Darmstadt
Germany
info@plexiglas.net
www.plexiglas.net
www.evonik.com

Evonik. Power to create.